

INSTALLATION GUIDE

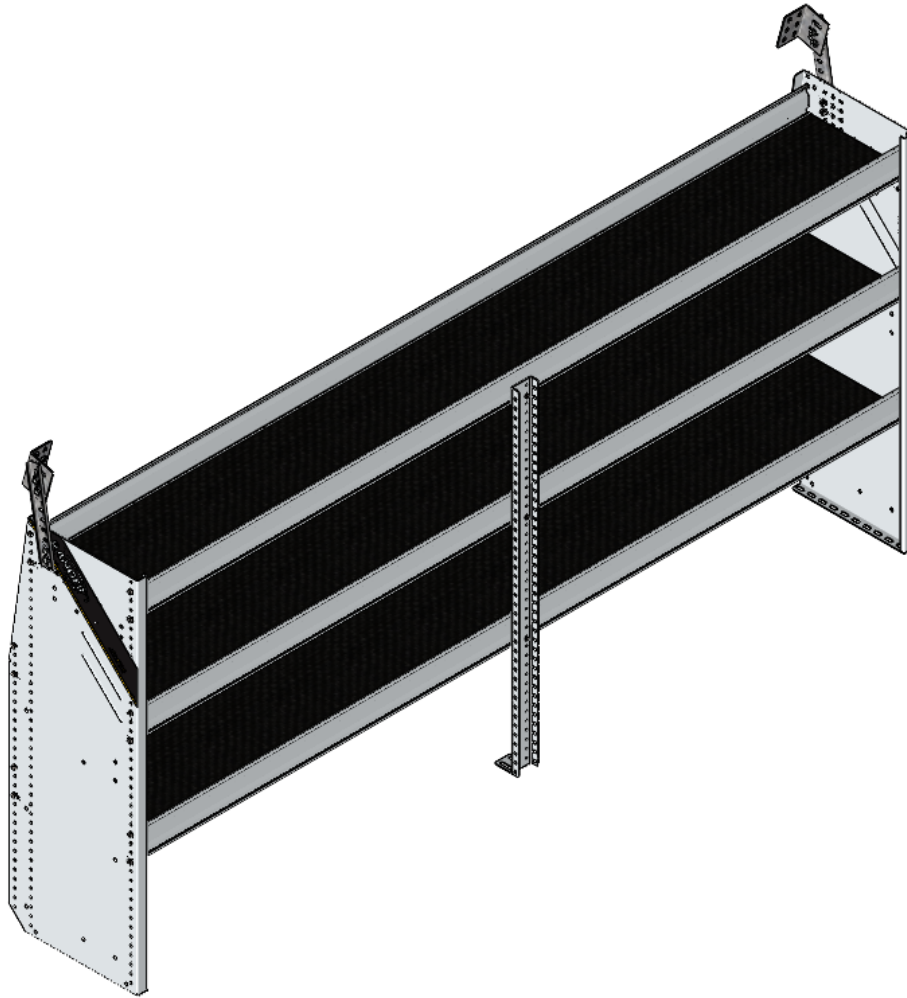

N4-RA84-3C Shelving (ALUMINUM)

Transit Low Roof
Nissan NV Low Roof
GM Savana
Metris
Nissan NV200
City Express



Scan the QR code for
the digital Install Guide.

RANGER
DESIGN

QUICK START GUIDE

Unpack components and compare with the bill of materials.

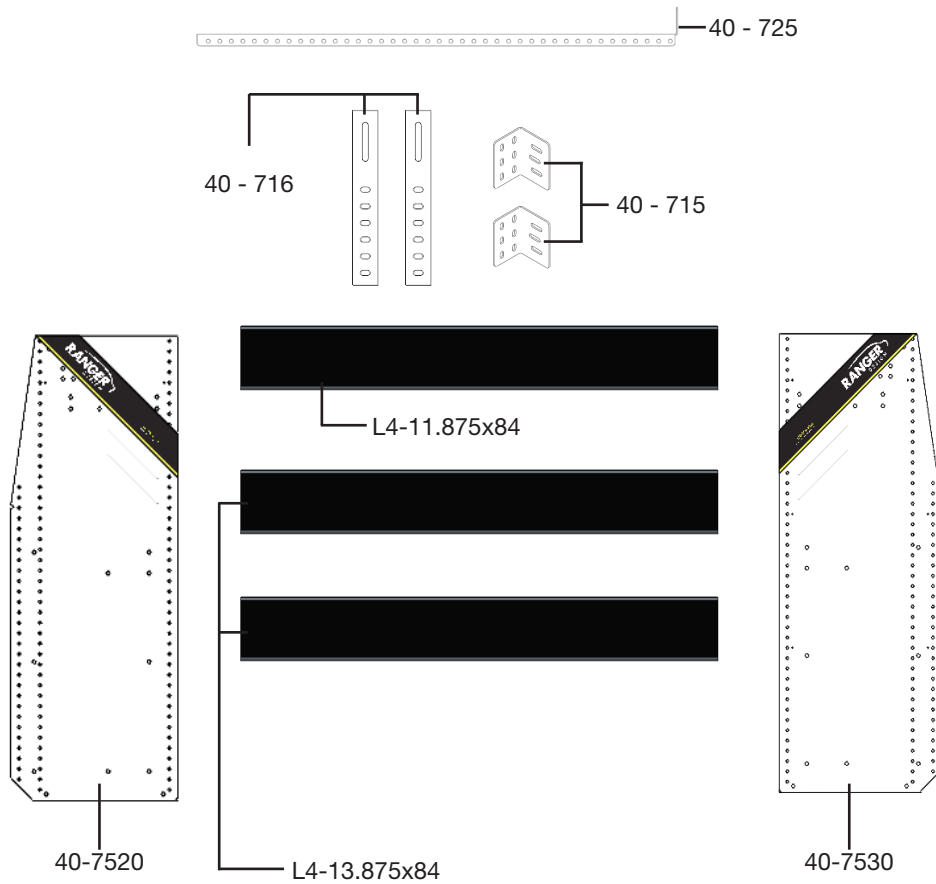

Verify all parts are present.

BILL OF MATERIALS

Item No.	Description	Qty.
40 - 715	Bracket Head	2
40 - 716	Bracket Arm	2
40-725	Center Post Low Roof	1
40 - 7520	N4 End Panel (Left)	1
40 - 7530	N4 End Panel (Right)	1
L4-11.875x84	Shelf Tray, Composite, 12" x 84"	1
L4-13.875x84	Shelf Tray, Composite, 14" x 84"	2
94 - 4028	Assembly Fastener Kit	1
96 - 4028	Install Fastener Kit	1

WARNING

Before the installation, carefully read the supplied installation guide to avoid possible injuries and damages resulting from incorrect installation. Always keep the installation guide in an accessible location at all times for reference during installation.

Installers must always wear appropriate safety gear during installation. This may include but is not limited to gloves, steel toed shoes, and safety glasses.

Drilling is required to complete this install. Before drilling, ensure that you will not hit any critical parts of the vehicle like the gas tank, wiring harness, or hose. Consult OEM vehicle or documentation as necessary. When drilling, use a drill collar to reduce risk of damage to the vehicle.

This installation guide provides general installation instructions and best practices. However, various vehicles and product install locations may require additional steps. It is the installers responsibility to ensure the install is safe and secure. For further questions please contact us at 1-800-565-5321.

Phase 1 - Assembly

- 1.1 Setup..... 3 - 4
- 1.2 Shelf Assembly..... 5

Phase 2 - Installation

- 2.1 Bracket installation to shelf..... 6
- 2.2 Post to shelf installation 6
- 3.1 Mark, drill, install plusnuts to vehicle wall..... 7
- 4.1 Plusnut installation directly to van metal floor..... 7
- 4.2 Shelf installation directly to van metal floor..... 8
- 5.1 Shelf installation to 6541 Series E-floor..... 8
- 5.2 Shelf installation to 6540 Series floor 9
- 6.1 Brackets directly to vehicle 9
- 6.2 Brackets install to ranger mounting tracks..... 10
- 7.1 Verify and tighten all fasteners..... 10

Appendix

- How to use plusnut gun and tool 11

REQUIRED ITEMS

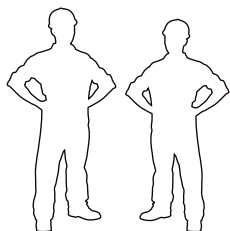

2
PERSONS

- Cordless Impact
- Cordless Drill
- Tape Measure
- Marker
- 1/2" Socket
- 1/2" Drill Bit w/ Drill Collar (Set at 1/2")
- 3/8" Driver Bit
- Plusnut Tool / Plusnut Gun (5/16")
- Allen Key 8mm
- 7/16" Drill Bit

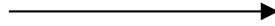

94 - 4028 Fastener Kit



Fastener Assembly

- 8x  # 90-204 Hex Bolt
5/16"-18 x 3/4"
GR-5 ZINC
- 6x  # 92-200 Screw HFH
#10 - 16 x 3/4"
ZINC
- 24x  # 92-102 Screw HWH
#14 x 1"
ZINC
- 8x  # 94-116 Serrated Nut
5/16"-18
ZINC
- 8x  # 98-116 Flat Washer
5/16" - 18 x 1"
ZINC

8x

 #90-204 Hex Bolt 5/16" x 3/4"
 #98-116 Flat Washer
 #94-116 Serrated Nut

6x

 #92-200 Screw #10 - 16 x 3/4"

24x

 #92-102 Screw #14 x 1"

96 - 4028 Fastener Kit







Fastener Assembly

- 6x  # 90-011 Hex Bolt
5/16"-18 x 1-3/4"
GR-5 ZINC
- 4x  # 90-212 Hex Bolt
5/16"-18 x 1-1/4"
GR-5 ZINC
- 10x  # 94-132 Plusnut 5/16"
- 10x  # 98-116 Flat Washer
5/16", O.D. 7/8"
ZINC
- 10x  # 98-122 Lock Washer
5/16"
ZINC
- 6x  # 98-157 Spacer
0.375" ID, x 1.0" OD x 0.25" LONG
NYLON

4x

 #90-212 Hex Bolt 5/16" x 1-1/4"
 #98-122 Lock Washer
 #98-116 Flat Washer
 #94-132 5/16" Plusnut

6x

 #90-011 Hex Bolt 5/16" x 1-3/4"
 #98-122 Lock Washer
 #98-116 Flat Washer
 #98-157 Spacers
(QTY = GAP BETWEEN FLOOR AND END PANEL)
 #94-132 5/16" Plusnut

PHASE 1 – SHELF ASSEMBLY

1.2 ASSEMBLY

- Attach both panels to the shelf trays.

NOTE: You can adjust the bottom shelf location to maximize or minimize your space over the wheel. If needed, line up the bottom shelf tray bolt with the shelf position guide to ensure clearing all wheel wells.

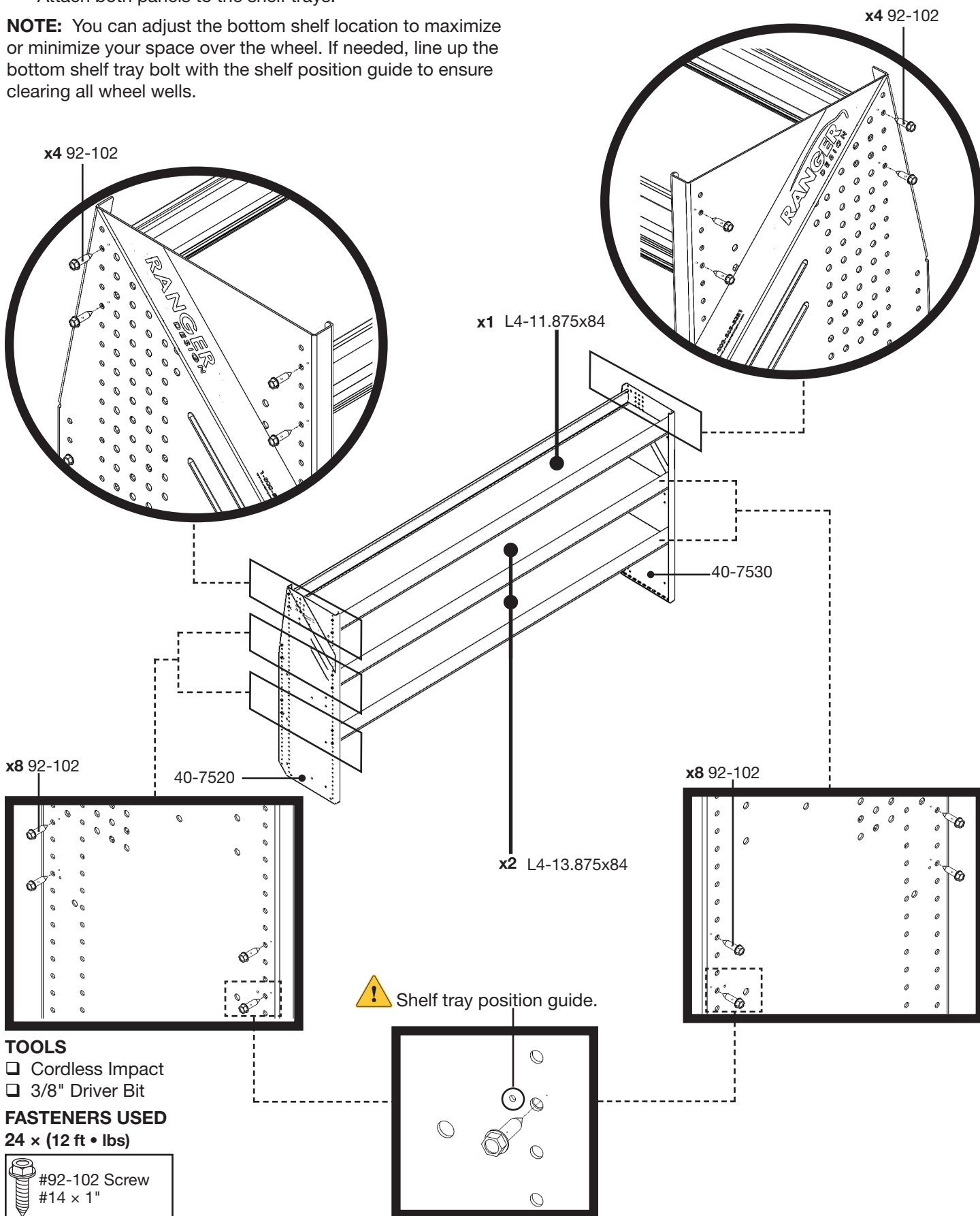

TOOLS

- Cordless Impact
- 3/8" Driver Bit

FASTENERS USED

24 x (12 ft • lbs)

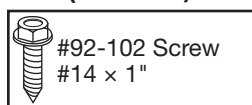

PHASE 2- INSTALLATION

2.1 BRACKET INSTALLATION TO SHELF

- Assemble bracket head and arm.
- Install brackets on to the panel aligning the brackets to the horizontal rim of the vehicle.
- Bracket head can be placed in either orientation for install flexibility.

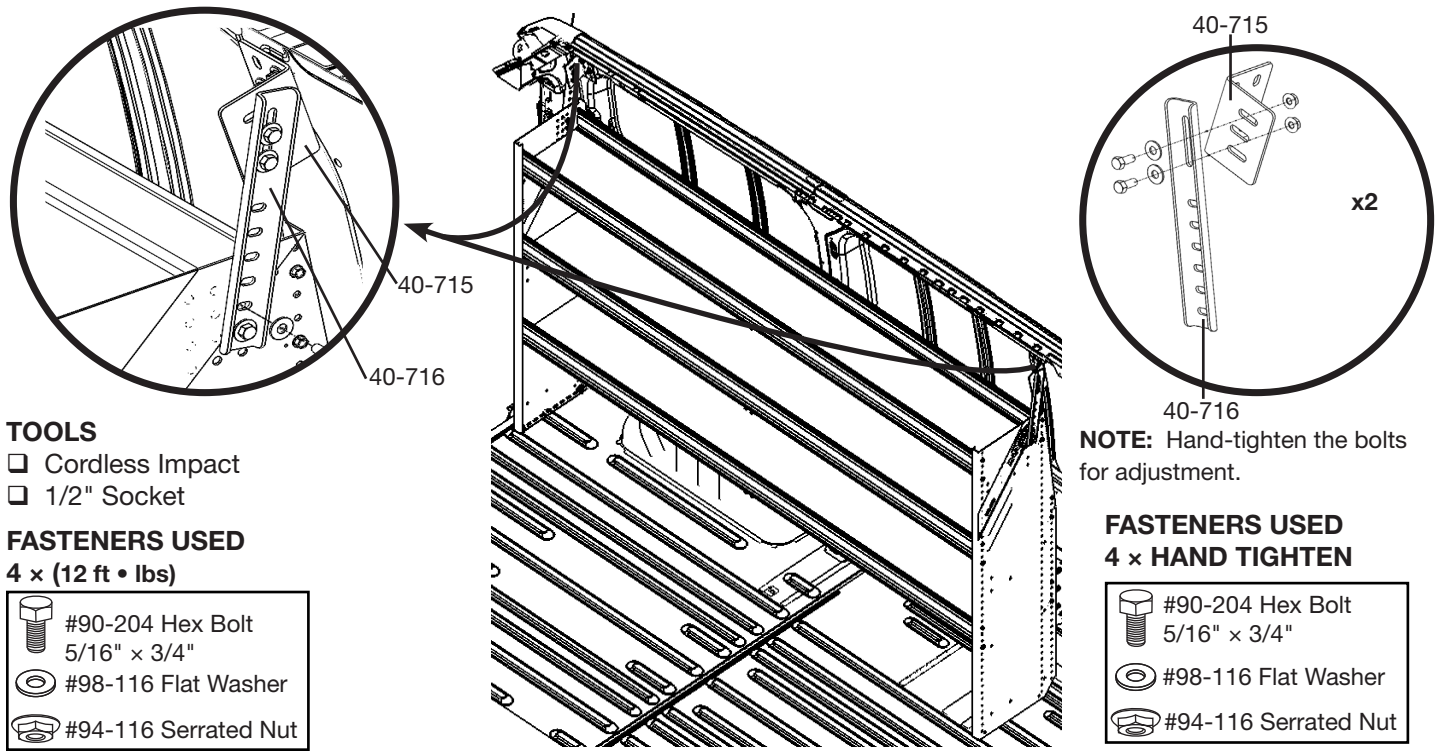

TOOLS

- ☐ Cordless Impact
- ☐ 1/2" Socket

FASTENERS USED

4 x (12 ft • lbs)

- #90-204 Hex Bolt
5/16" x 3/4"
- #98-116 Flat Washer
- #94-116 Serrated Nut

FASTENERS USED

4 x HAND TIGHTEN

- #90-204 Hex Bolt
5/16" x 3/4"
- #98-116 Flat Washer
- #94-116 Serrated Nut

2.2 POST TO SHELF INSTALLATION

- Fasten the center post to the center of every shelf tray using provided hardware.

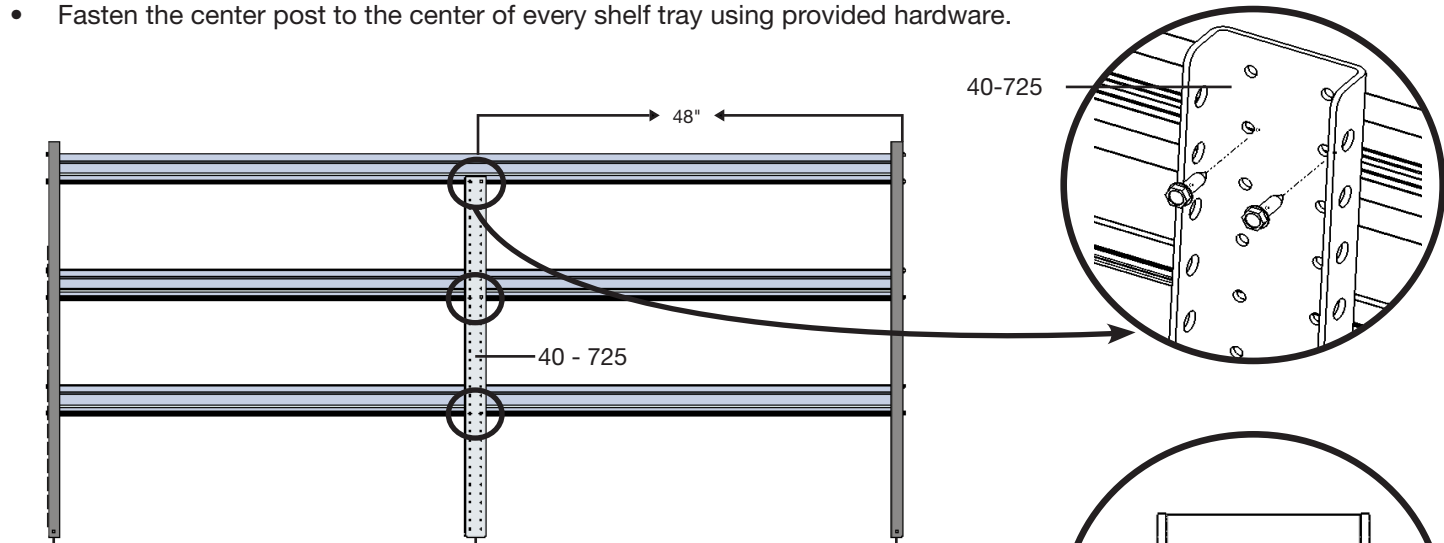

NOTE: The bottom flange of the center post needs to be leveled with the bottom of the end panel.

TOOLS

- ☐ Cordless Impact
- ☐ 3/8" Driver Bit

FASTENERS USED

6 x

- #92-200 Screw #10 - 16 x 3/4"

3.1 MARK, DRILL, INSTALL PLUS NUTS TO VEHICLE WALL

- Place the shelf to the preferred location.
- Mark 4 holes using a marker.
- Drill and install plusnuts.

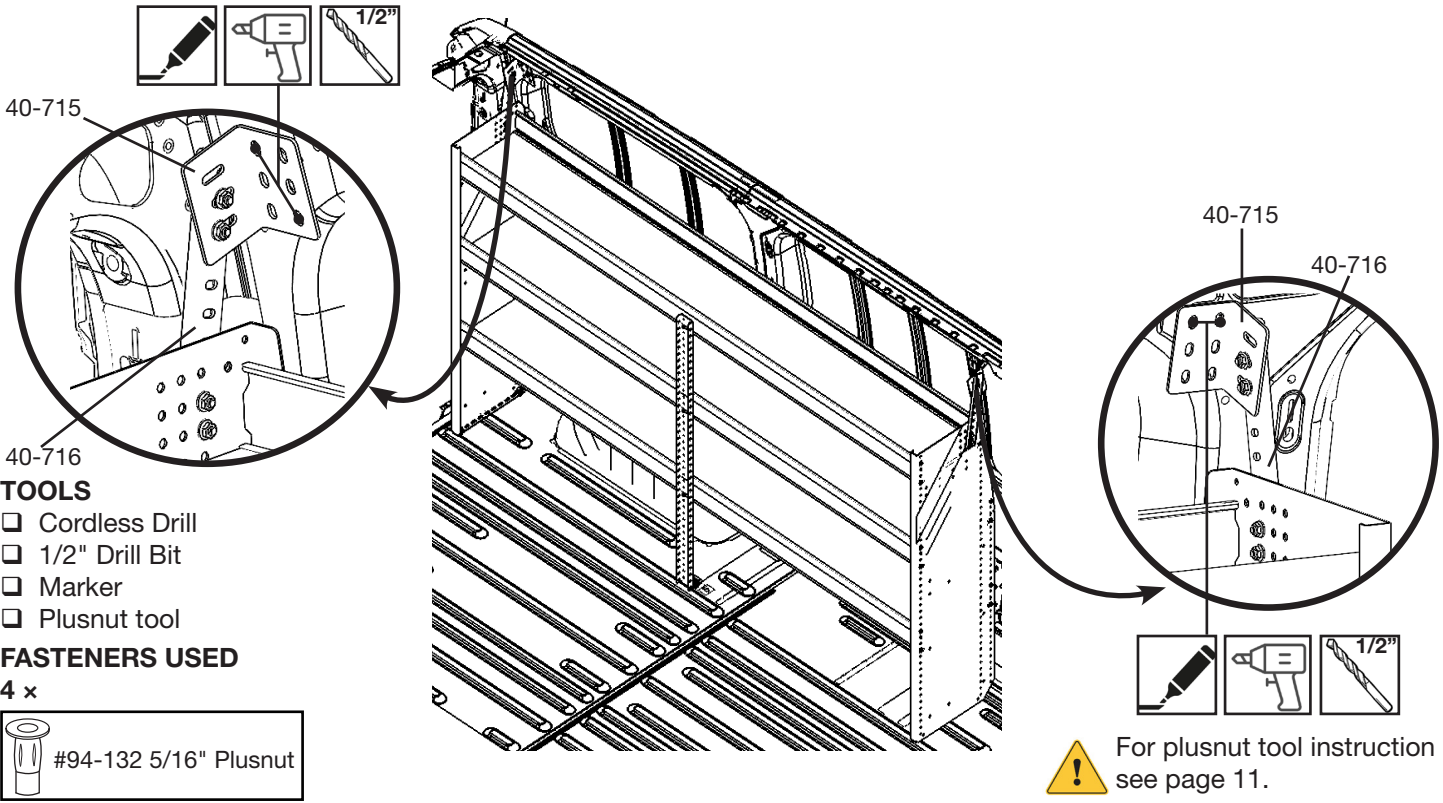

TOOLS

- Cordless Drill
- 1/2" Drill Bit
- Marker
- Plusnut tool

FASTENERS USED

4 x

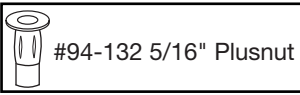

4.1 PLUSNUT INSTALLATION DIRECTLY TO VAN METAL FLOOR

- Using the shelf as template mark plusnut location using maker.
- Drill 6 holes using a 1/2" drill and install plusnuts.

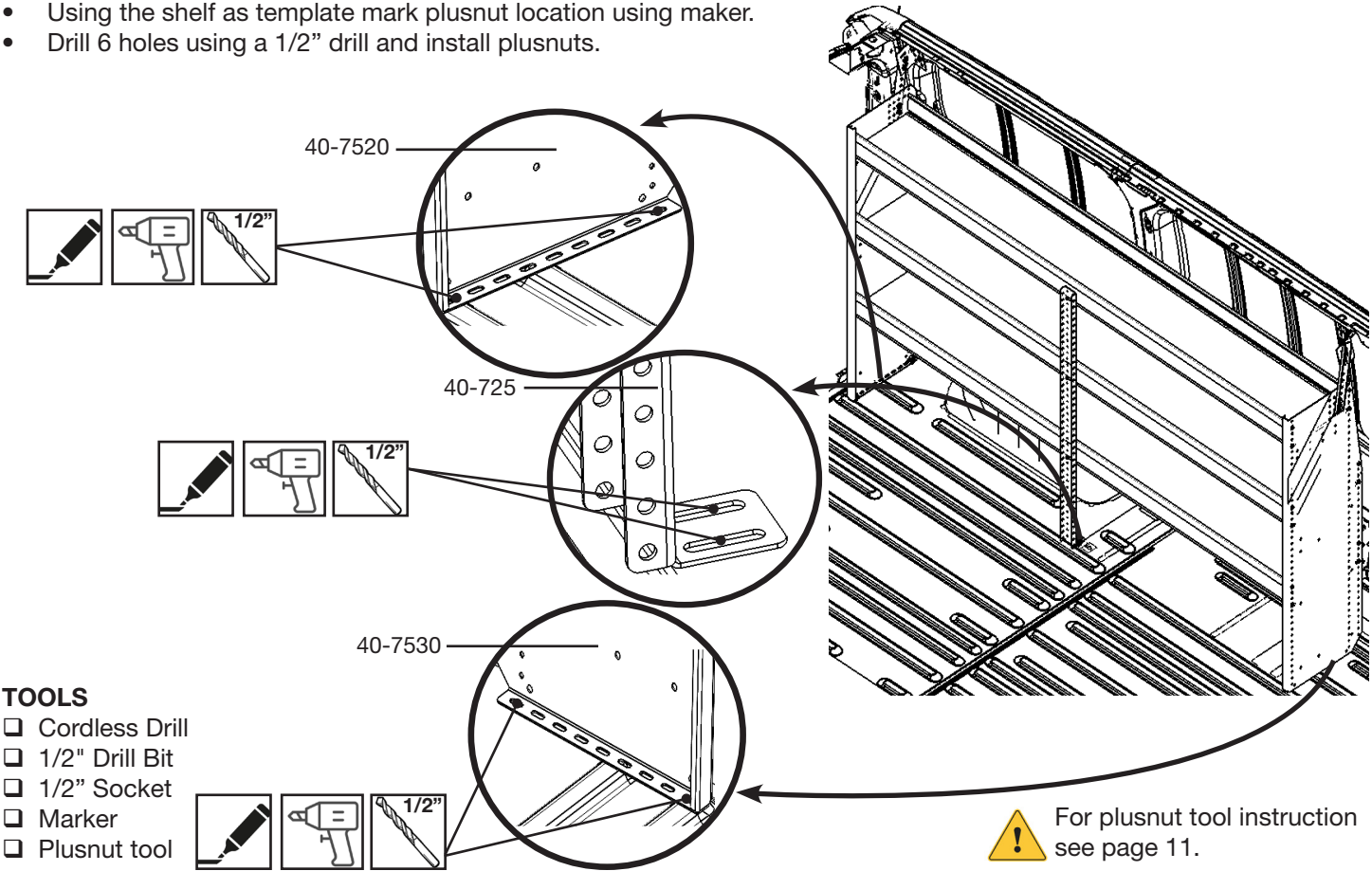

TOOLS

- Cordless Drill
- 1/2" Drill Bit
- 1/2" Socket
- Marker
- Plusnut tool

4.2 SHELF INSTALLATION DIRECTLY TO VAN METAL FLOOR

- Align the panel holes to the plusnuts, then install the end panels to the floor using proper hardware provided.

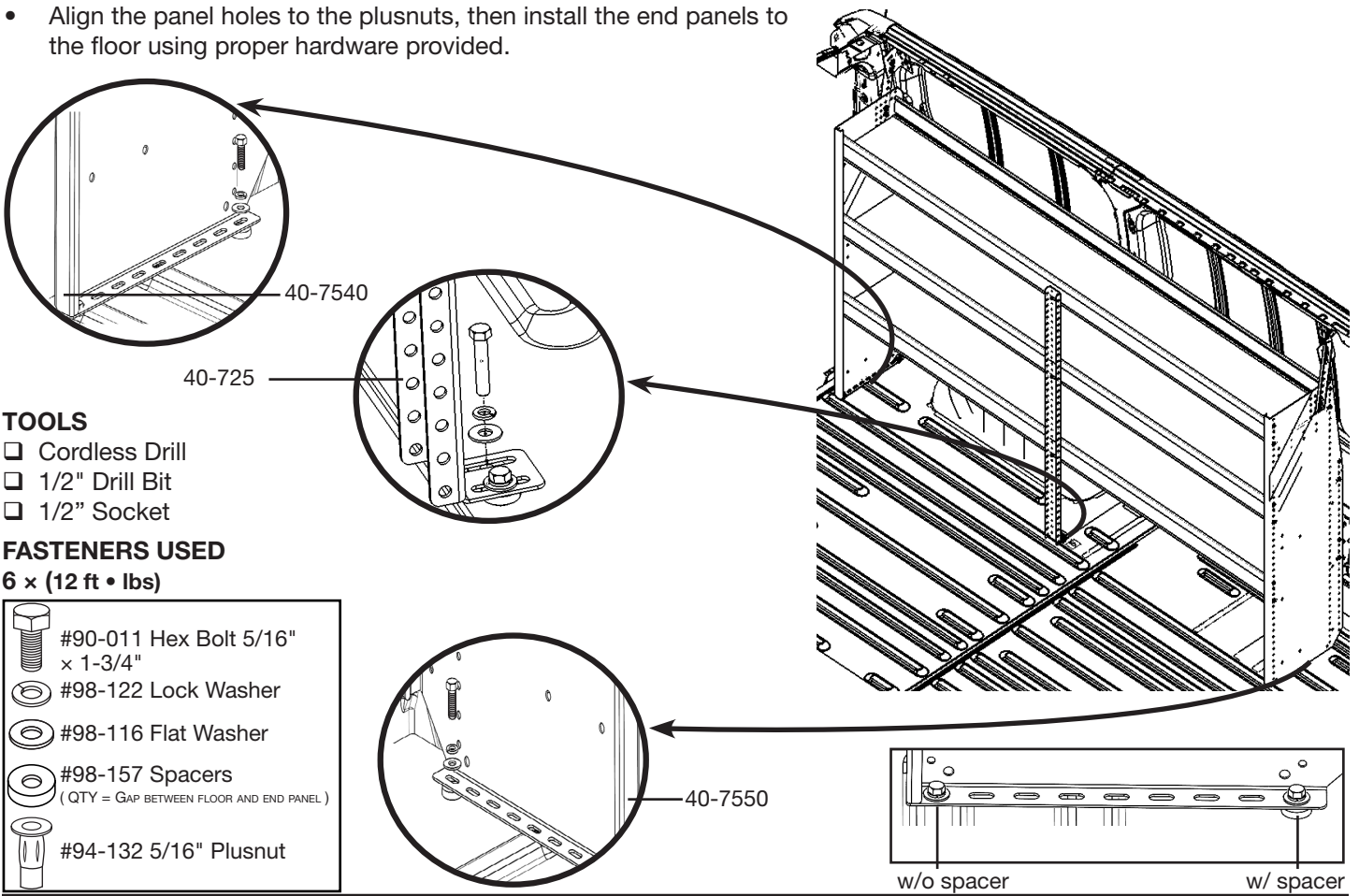

TOOLS

- Cordless Drill
- 1/2" Drill Bit
- 1/2" Socket

FASTENERS USED

6 x (12 ft • lbs)

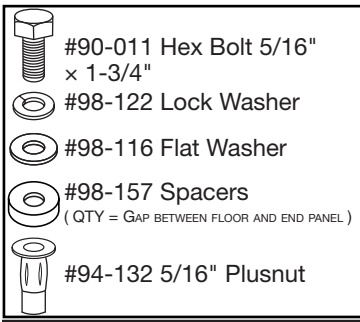

5.1 SHELF INSTALLATION TO 6541 SERIES E-FLOOR

- Using the shelf as template mark wood insert location using marker.
- Drill holes using 7/16" drill bit and install wood inserts using allen key.
- Fasten shelf using hardware provided with the floor.

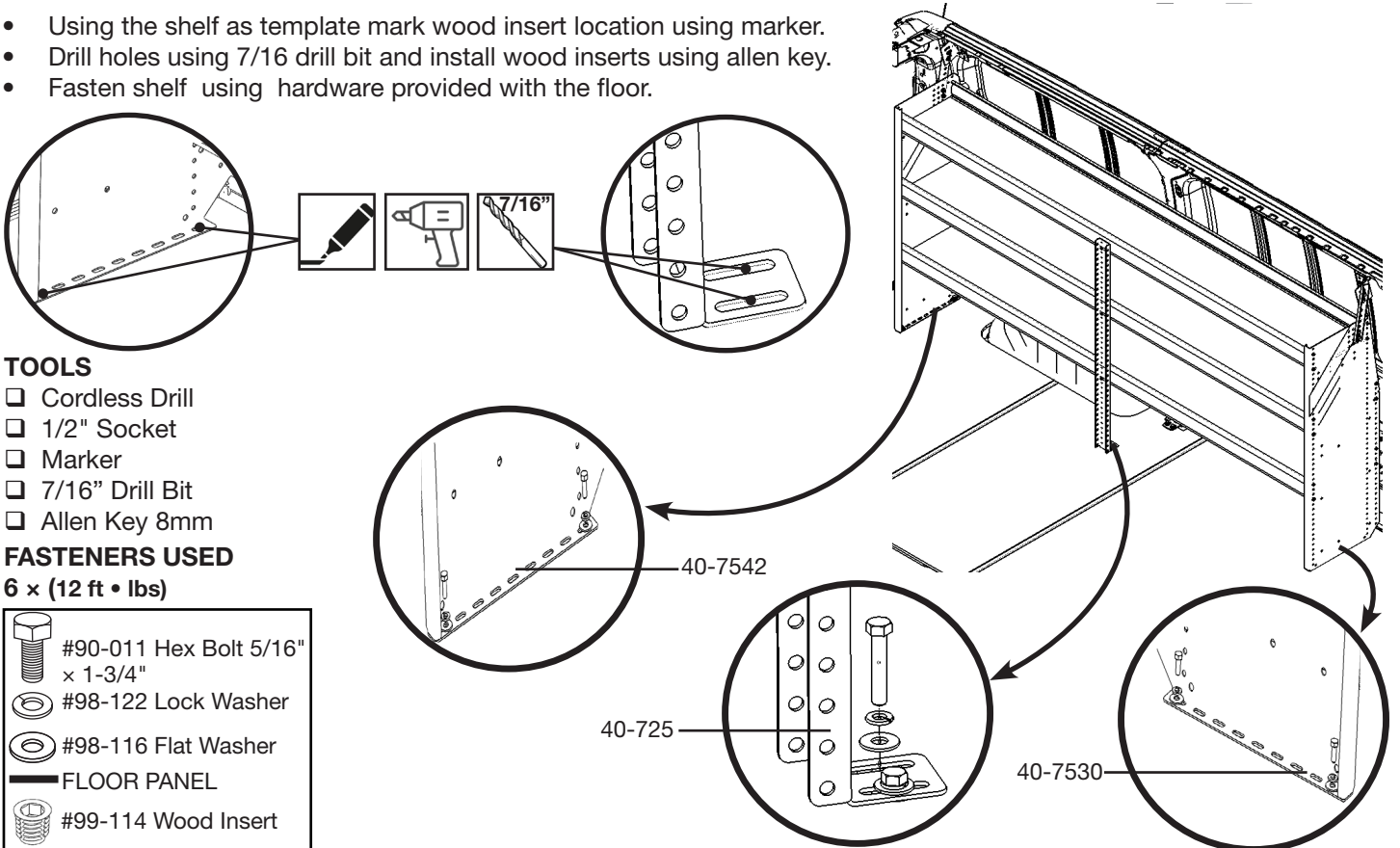

TOOLS

- Cordless Drill
- 1/2" Socket
- Marker
- 7/16" Drill Bit
- Allen Key 8mm

FASTENERS USED

6 x (12 ft • lbs)

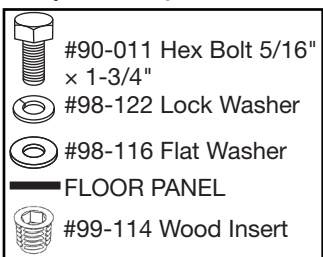

5.2 SHELF INSTALLATION TO 6540 SERIES FLOOR





- Slide 4 carriage bolts into the mounting track.
- Install the front end of the shelf and post by fastening the carriage bolt on to the panel and secure the shelf and post using the provided hardware.
- Secure the back end of the shelf by using a tapping screw into each panel on to the floor.

TOOLS

- ☐ Cordless Impact
- ☐ 3/8" Driver Bit
- ☐ 1/2" Socket

FASTENERS USED

4 x (12 ft • lbs)

-  #90-490 Carriage Bolt 5/16" x 1"
-  #98-116 Lock Washer
-  #98-122 Flat Washer
-  #94-104 Hex Nut

FASTENERS USED

2 x (12 ft • lbs)

-  #92-102 Screw 1"

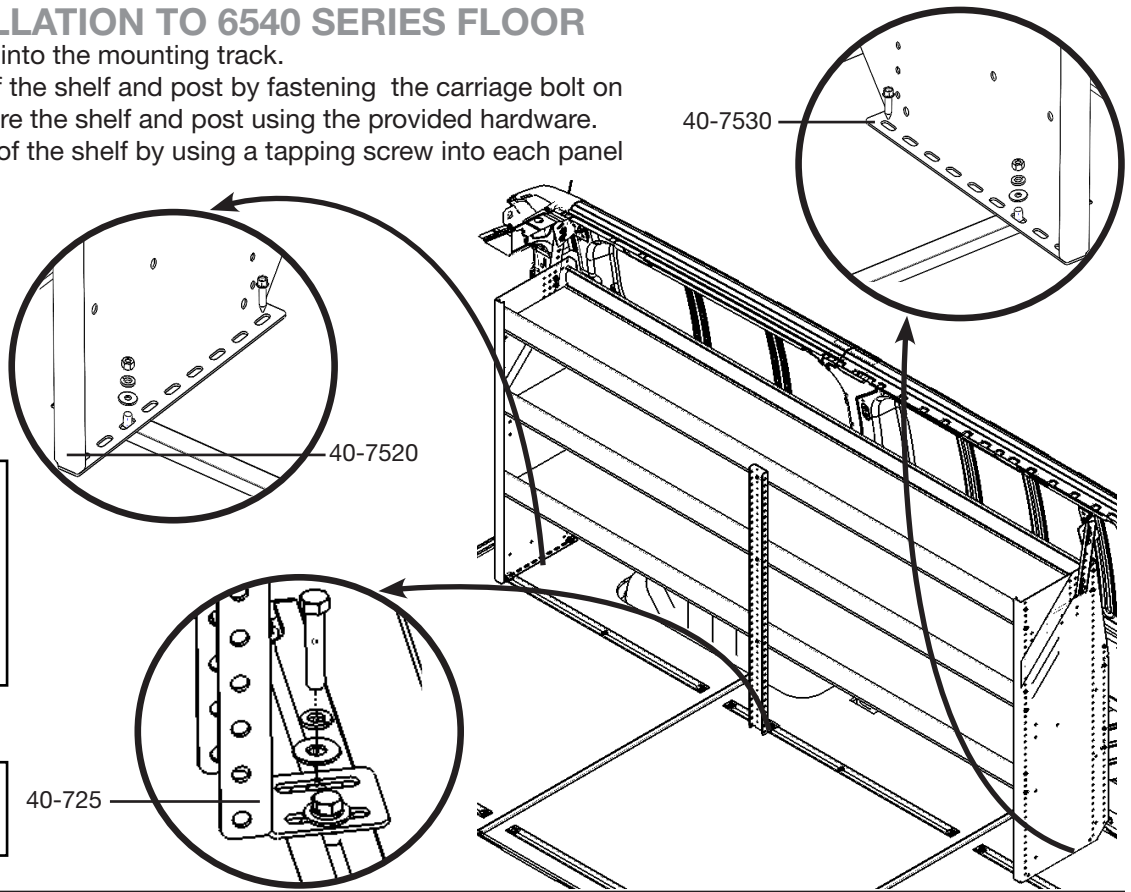

6.1 BRACKET INSTALL DIRECTLY TO VEHICLE

- Bolt brackets to plusnuts using proper hardware provided.

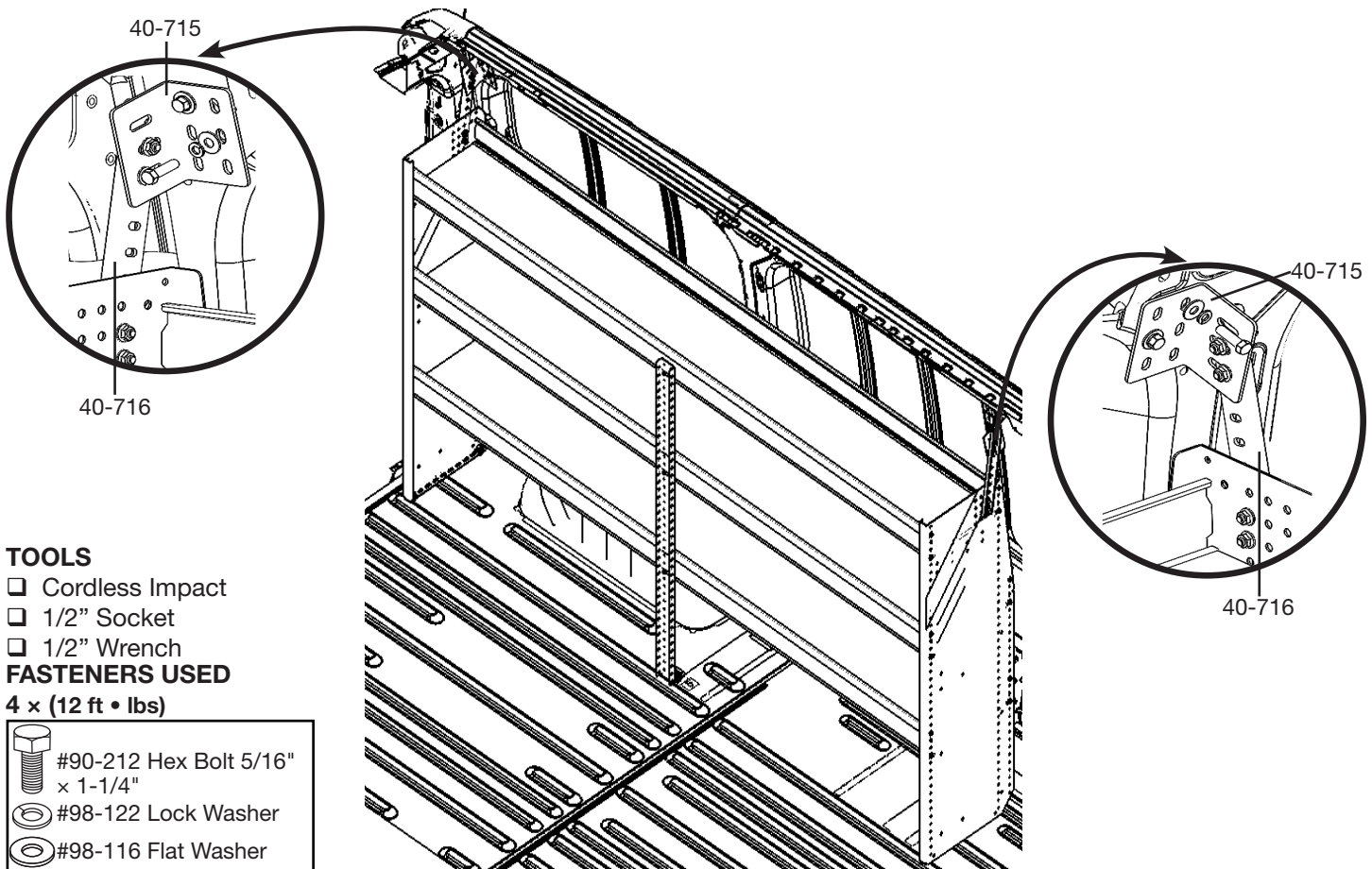



TOOLS

- ☐ Cordless Impact
- ☐ 1/2" Socket
- ☐ 1/2" Wrench

FASTENERS USED

4 x (12 ft • lbs)

-  #90-212 Hex Bolt 5/16" x 1-1/4"
-  #98-122 Lock Washer
-  #98-116 Flat Washer

6.2 BRACKET INSTALL TO RANGER MOUNTING TRACKS

- Align the wall brackets to the wall mounting track kits.
- Install the wall brackets to the wall mounting track kits using channel nuts.







For mounting track install guide, visit our website

TOOLS

- Cordless Impact
- 1/2" Socket

FASTENERS USED

4 x (12 ft • lbs)

	#90-208 Hex Bolt 5/16" x 1"
	#98-122 Lock Washer
	#98-116 Flat Washer
	#94-150 Channel Nut

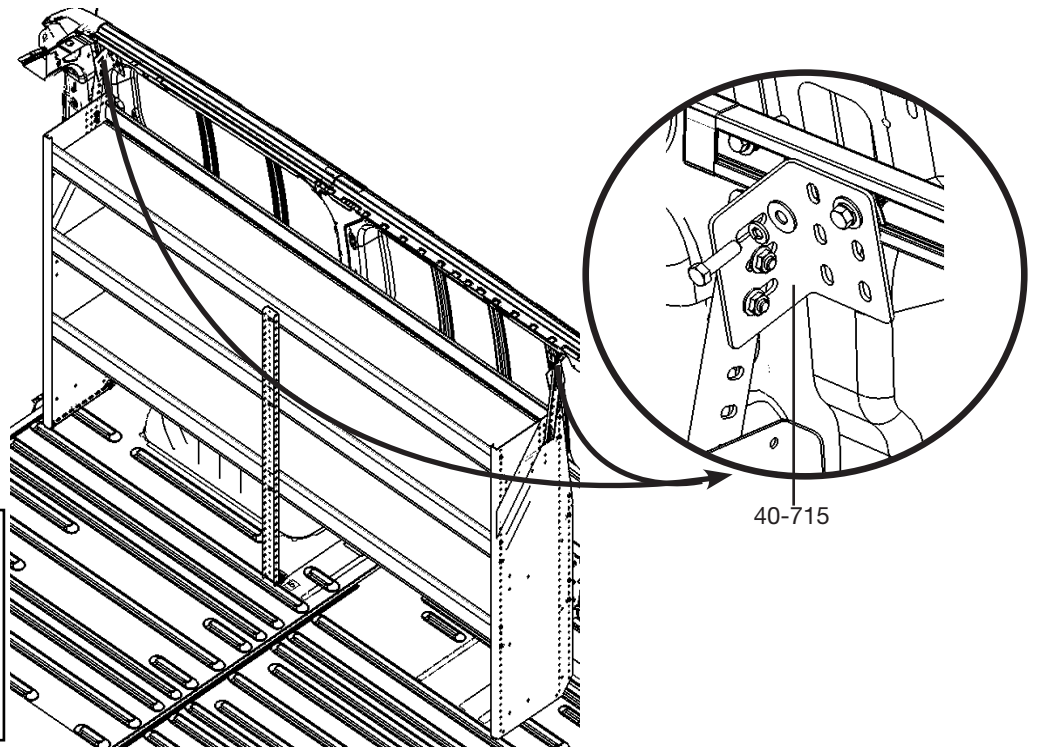

7.1 VERIFY AND TIGHTEN ALL FASTENERS

- Verify and inspect that all fasteners are tightened to recommended torque specification.

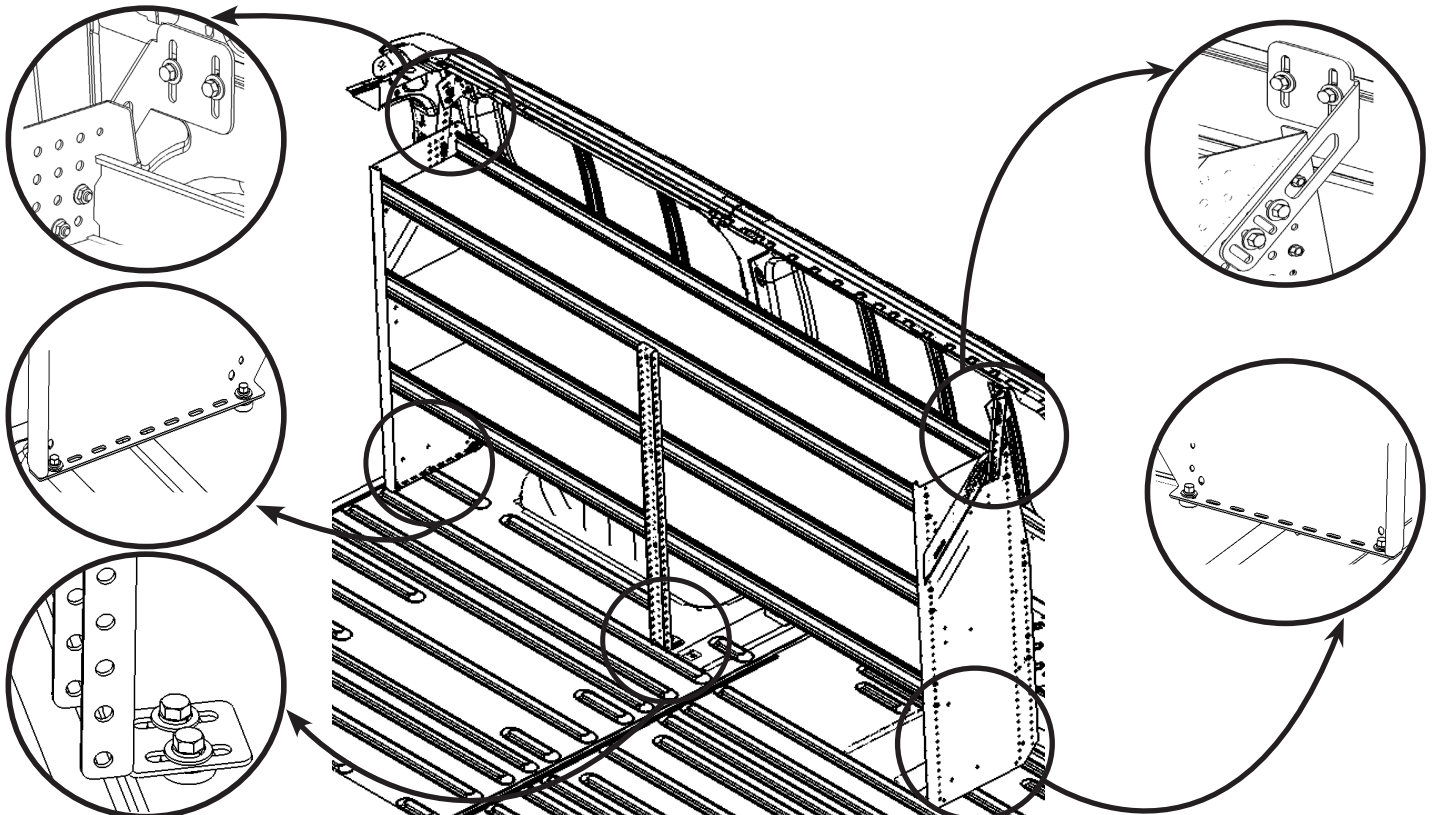

“You have successfully installed your composite aluminum shelving, thank you for doing business with us.”

For any feedback or suggestions, you may have, please contact: cs@rangerdesign.com

APPENDIX:

• USING PLUSNUT GUN

STEP: Put the plusnut on the plusnut gun, then attach the plus nut in the hole by turning the gun forward until the plus nut locks, then remove the gun by turning in reverse.

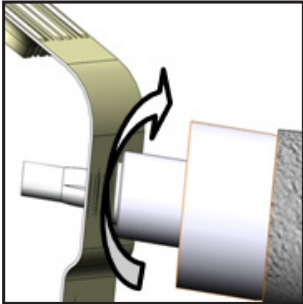

FORWARD

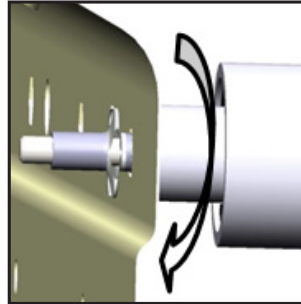

REVERSE

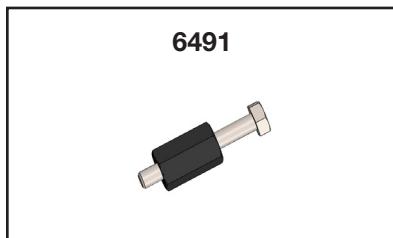

• USING THE 6491 PLUSNUT TOOL

NOTE: The hardware used for the 6491 plusnut tool is not included in the fastener bag. The 6491 plusnut tool can be ordered separately upon demand at no charge.



6491

HARDWARE USED

-  Flat washer 5/16"
-  Flat washer 5/16" BS x 7/8" OD

TOOLS

- Cordless Impact
- 1/2" Socket
- 9/16" Wrench

STEP 1:

Assemble the 6491 plusnut tool with the hardware needed, plus nut and the 9/16" wrench as shown.



STEP 2:

Attach the plus nut in the hole by turning the bolt forward using an impact with a 1/2" socket until the plusnut locks, then remove the bolt by turning the impact in reverse.

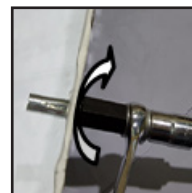

FORWARD



REVERSE